



RMSYS

12÷24 kV

Ring Main Unit



RMSYS

12÷24kV



Ring Main Unit

			Pag.
Generalities	Generalità	Généralités	02
Employment	Impiego	Emploi	03
Description	Descrizione	Description	04
Cable termination	Attacco cavo	Connexion cable	10
Norms and homologations	Norme e certificati	Normes et certificats	11
Electrical features	Caratteristiche elettriche	Caractéristiques électriques	12
Typical configuration	Configurazioni tipiche	Configurations typiques	13
Installation details	Dettagli di installazione	Details d'installation	19
Dimensional features	Caratteristiche dimensionali	Caractéristiques dimensionnelles	20



Generalities Generalità Généralités

RMSYS switchboard (Ring Main Unit - RMU) is composed by a monoblock partitioned into integrated operating units.

The stainless steel shell is absolutely sealed, and contains the switching device and all the live parts.

The possible combinations of 3 position rotary switches (close, open, earthed) with vacuum circuit breakers or fuses assure to protect the outgoing circuits and/or transformers.

Every operating unit contains a *plug-in* cable connection compartment.

A relief valve ensures the safety in the event of overpressure inside the container, in accordance with the standards IEC 62271-1; the pressure is constantly monitored by a manometer placed on the front.

The system is in keeping with the IEC Standards annex EE, relating to sealed pressure systems.

Il quadro **RMSYS** (Ring Main Unit - RMU) è costituito da un monoblocco suddiviso in unità operative integrate.

L'involucro, in acciaio inox, è completamente sigillato e racchiude al suo interno gli apparecchi di manovra e tutte le parti attive.

Le possibili combinazioni di sezionatori di manovra a tre posizioni (chiuso, aperto, messa a terra) con interruttori automatici sottovuoto o fusibili garantiscono la protezione dei trasformatori e/o delle linee uscenti.

In ciascuna unità operativa è presente uno scomparto adibito all'installazione degli attacchi cavo *plug-in*.

Una valvola di sfogo garantisce la sicurezza in caso di sovra pressione interna del contenitore, in accordo alle norme IEC 62271-1; la pressione è costantemente monitorata da un apposito manometro posto sul fronte.

Il sistema risponde alle normative CEI allegato EE, relative ai sistemi a pressione sigillata.

Le tableau **RMSYS** (Ring Main Unit - RMU) est constitué par un monobloc divisé en unités opérationnelles intégrées.

L'enveloppe, en acier inox, est complètement scellé et contient les dispositifs de commutation et tous les éléments actifs.

Les combinaisons possibles d'interrupteurs à trois positions (fermé, ouvert, mise à la terre) avec disjoncteurs sous vide ou fusibles assurent la protection des transformateurs et/ou des lignes en sortie.

En chacune unité opérationnelle se trouve un compartiment utilisé pour l'installation des attelages câbles *plug-in*.

Le monobloc en acier inox est équipé d'une valve de sûreté qui intervient dans le cas de surpressions internes, selon les normes IEC 62271-1; la pression est régulièrement surveillée par un spécial manomètre visible sur le front.

Le système est conforme aux Normes IEC annexe EE, concernant les systèmes à pression scellée.



Employment Impiego Emploi

RMSYS switchboards are used in MV secondary power distribution, public or private, with voltage up to 24kV.

Particularly they can be employed in power lines and transformers on ring networks.

I quadri **RMSYS** vengono utilizzati nelle reti di distribuzione secondaria di MT, pubbliche o private, con tensioni fino a 24kV.

Nello specifico, per la protezione e l'alimentazione di linee e trasformatori installati su una rete ad anello.

Les tableaux **RMSYS** sont utilisés dans les réseaux électrique de distribution secondaire de MT, publiques ou privées, avec des tensions jusqu'à 24kV.

En particulier, pour la protection et la puissance des lignes et des transformateurs installés sur un réseau en anneau.





RMSYS I-I-F type

RMSYS tipo I-I-F

RMSYS type I-I-F



1

On-load switch
Interruttore di manovra-sezionatore
Interrupteur

2

Connector for extension
Connettori per estensione
Connecteurs d'extension

3

Fuses
Fusibili
Fusibles

4

Bushing
Isolatori passanti
Isolateurs passants

5

Manometer
Manometro
Manomètre

6

Connector for extension
Connettori per estensione
Connecteurs d'extension

7

Fuses
Fusibili
Fusibles

8

Connector for extension
Connettori per estensione
Connecteurs d'extension



RMSYS I-I-V type

RMSYS tipo I-I-V

RMSYS type I-I-V



7

Protection relay
Relè di protezione
Relais de protection

2

Vacuum circuit breaker
Interruttore sottovuoto
Disjoncteur sous vide

4

Bushing
Isolatori passanti
Isolateurs passants

6

Manometer
Manometro
Manomètre

5

Current transformers
Trasformatori di corrente
Transformateurs de courant





1 On-load switch Interruttore di manovra-sezionatore Interrupteur

The switch has three different positions: close, open and earthed, with an effective locking system that prevents incorrect operations.

The operating mechanism can be motorized.

L'apparecchio può assumere tre posizioni, chiuso, aperto e messo a terra, presentando un efficace sistema di interblocco che previene manovre errate.

Il comando può essere motorizzato.

L'appareil peut avoir trois positions: fermé, ouvert et mise à la terre, et il est doté d'un efficace naturel système de verrouillage qui prévient les manoeuvres incorrectes.

La commande peut être motorisée.



2 Vacuum circuit breaker Interruttore sottovuoto Disjoncteur sous vide

Consisting of three vacuum chambers operated simultaneously by a control located on the front panel.

The operating mechanism can be motorized.

Composto da tre camere sottovuoto operate simultaneamente da un comando posto sul fronte del quadro.

Il comando può essere motorizzato.

Composé par trois chambres à vide fonctionnant simultanément par une commande située sur le front du panneau.

La commande peut être motorisée.

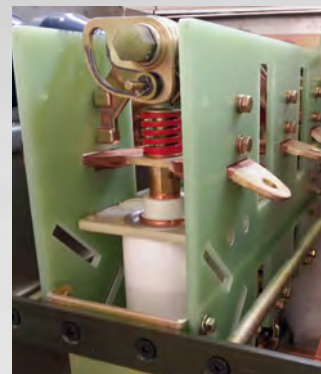

3 Fuses Fusibili Fusibles

Selection table Tabella di scelta Tableau de sélection										
Rated voltage Tensione nominale Tension nominal	Operating voltage Tensione di esercizio Tension de service	Transformer rating Potenza trasformatore Puissance transformateur								
		100	160	250	400	630	800	1000	1250	
12	6	25	32	50	63	100	125	/	/	
	6.6	25	32	50	63	80	100	125	/	
	10	16	25	32	50	63	80	100	125	
	11	16	20	25	40	50	63	80	100	
24	13.8	10	16	25	40	50	50	63	100	
	15	10	16	25	32	50	50	63	80	
	20	10	16	20	25	40	40	63	63	
	22	10	10	16	25	40	40	50	63	



Can be used DIN type fuses | Possono essere impiegati fusibili tipo DIN | Peuvent être utilisés fusibles de type DIN



Bushing Isolatori passanti Isolateurs passants

4



Bushing type "C" in keeping with Norms CEI EN 50181 (630A 20kA-3s bolted M.16).

Isolatori passanti tipo "C" come da norma CEI EN 50181 (630A 20kA-3s imbullonato M.16).

Isolateurs passants type "C" conforme aux Normes CEI EN 50181 (630A 20kA-3s bullonné M.16).

Current transformers Trasformatori di corrente Transformateurs de courant

5



They provide to the relay the current signal to be elaborated and the necessary energy to power it and the shunt opening release. They can have a primary current of 50A, 100A or 150A.

Forniscono al relè il segnale di corrente da elaborare e l'energia necessaria per l'alimentazione dello stesso, nonché dello sganciatore di apertura. Possono avere correnti primarie di 50A, 100A oppure 150A.

Ils fournissent au relais le signal de courant à élaborer et l'énergie nécessaire pour alimenter soit le relais même soit le déclencheur d'ouverture. Ils peuvent avoir une courant primaire de 50A, 100A ou 150A.

Manometer Manometro Manomètre

6



The pressure inside the tank is constantly monitored by a manometer placed on the front.

La pressione all'interno dell'involucro è costantemente monitorata da un apposito manometro posto sul fronte.

La pression à l'intérieur de l'enveloppe est régulièrement surveillée par un spécial manomètre visible sur le front.

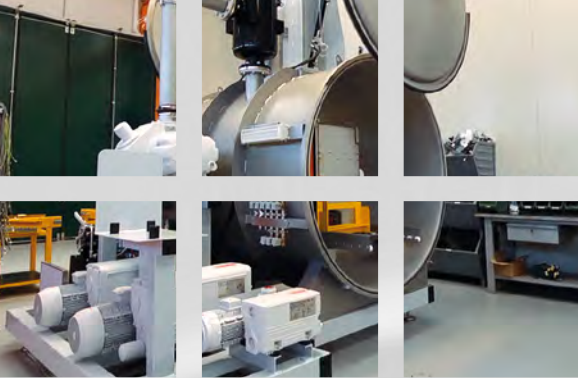

7

Protection relay Relè di protezione Relais de protection



Threshold Soglia Seuil	Features Caratteristiche Caractéristiques	Current regulation Regolazione corrente Régulation courant	Timing Temporizzazione Timing	Notes Note Note
51	Normal Inverse1 (IEC "A") Normal Inverse2 Very Inverse (IEC "B") Extremely Inverse (IEC "C") Long Time Inverse Define Time	20 ÷ 200% In in step di 1%	0,01 ÷ 1,00s in step di 0,01s	
50	Define Time	100 ÷ 3000% In in step di 100%	Instantaneous Istantaneo Instantané <60ms	
51N	Normal Inverse1 (IEC "A") Normal Inverse2 Very Inverse (IEC "B") Extremely Inverse (IEC "C") Long Time Inverse Define Time	10 ÷ 80% In in step di 1%	0,01 ÷ 1,00s in step di 0,01s	Minimum 20% In on a phase or 10% In on two phases Minimo 20% In su una fase oppure 10% In su due fasi Minimum 20% In sur une phase ou 10% In sur deux phases
50N	Define Time	100 ÷ 1200% In in step di 100%	Instantaneous Istantaneo Instantané <60ms	

Protection relay insertion Inserzione relè di protezione Câblage relais de protection

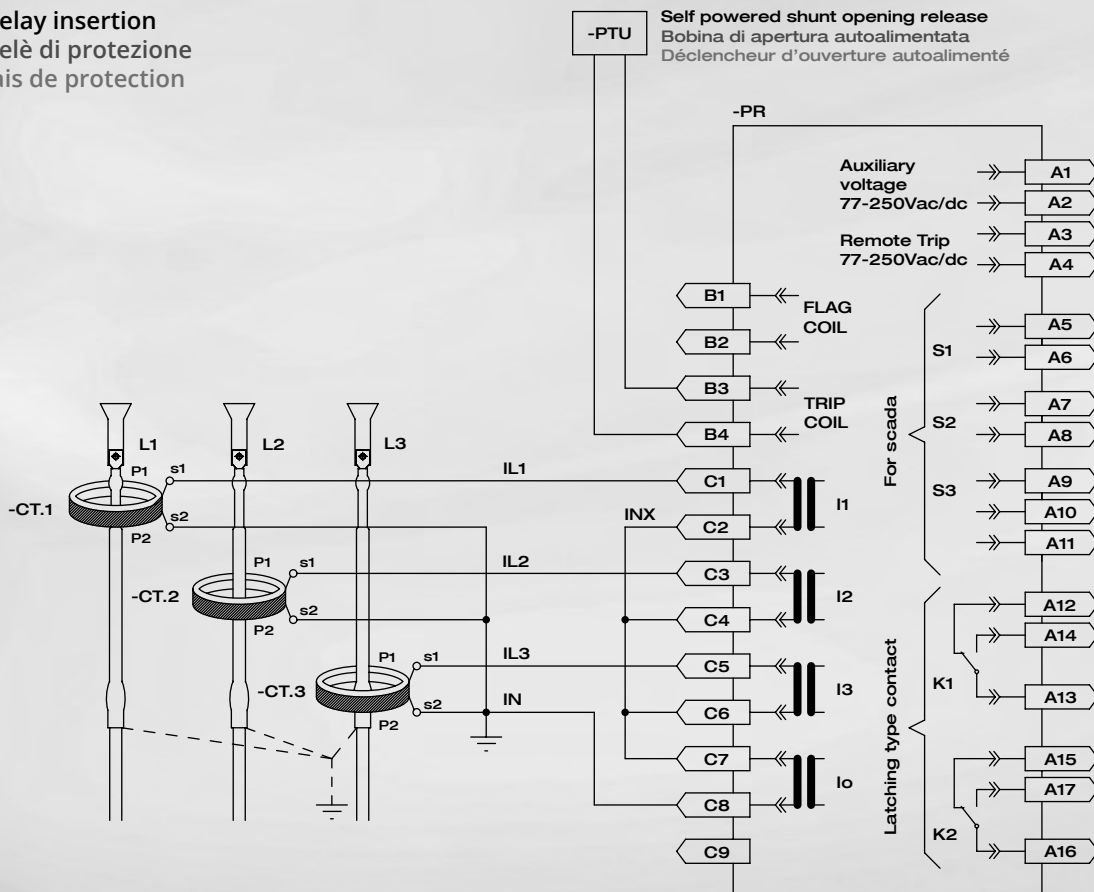



Connector for extension Connettori per estensione Connecteurs pour extension

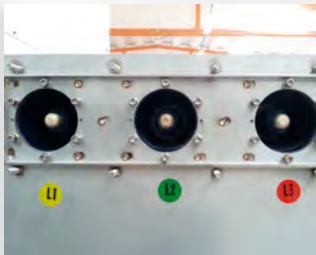

On request, all the units can be arranged for the extension both on right and left side.

To allow the coupling of the modules are provided appropriate accessories.

Su richiesta, tutte le unità possono essere predisposte per l'estensione sia a destra che a sinistra.

Per consentire l'accoppiamento dei moduli vengono forniti appositi accessori.

Sur demande, toutes les unités peuvent être prédisposés pour l'extension soit à droite qu'à gauche.

Pour permettre le couplage des modules sont fournis des accessoires appropriés.

Coupling accessories Accessori per accoppiamento Accessoires des couplage



Insulated connectors for extension
Connettori isolanti per estensione
Connecteurs isolés pour l'extension



Insulated plugs and closing cover
Tappi isolanti e piastre di chiusura
Bouchons isolant et couvercle



Extended bushing for metering module
Connettore estensibile per modulo misure
Connecteur extensible pour module mesure

The extensible modules are supplied with insulated plugs and closing cover.
Tutti i moduli estensibili sono forniti con appositi tappi isolanti e piastre di chiusura.
Les modules extensibles sont fournis avec des bouchons isolant et couvercle de fermeture.

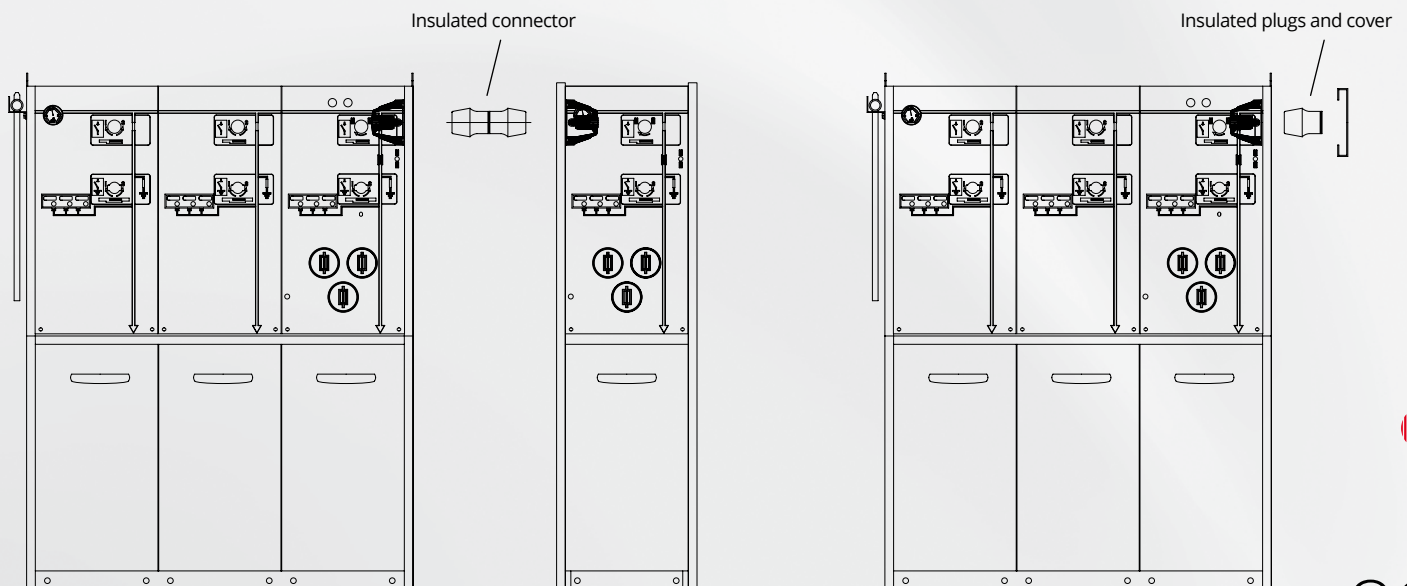

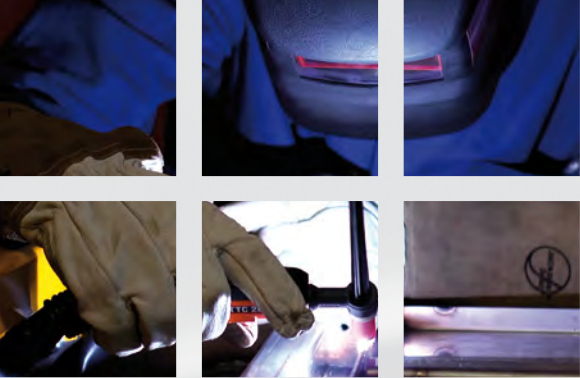

Cable termination

Attacco cavo

Connexion câble

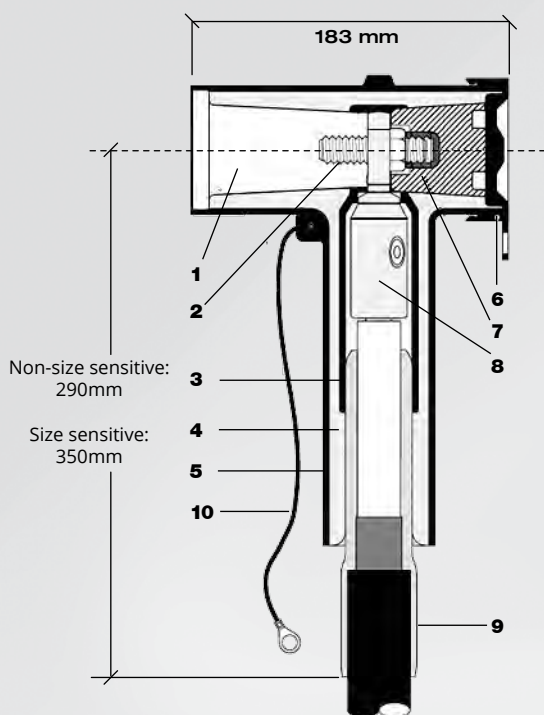

- 1** Interface type "C" 630A as described by CENELEC EN 50180 and 50181
Interfaccia tipo "C" 630A come descritto dal CENELEC EN 50180 e 50181
Type d'interface "C" 630A comme décrit par le CENELEC EN 50180 et 50181
- 2** Clamping screw
Vite di serraggio
Vis de serrage
- 3** Conductive EPDM insert
Inserto conduttore EPDM
Élément conducteur EPDM
- 4** Insulating EPDM layer moulded between the insert and the jacket
Strato isolante EPDM stampato tra l'inserto e la guaina
Couche isolant EPDM moulé entre l'élément et l'enveloppe
- 5** Conductive EPDM jacket
Guaina conduttiva EPDM
Enveloppe conductive EPDM
- 6** Conductive rubber cap
Cappuccio in gomma conduttiva
Bouchon en gomme conductive
- 7** Basic insulating plug
Spina isolante base
Fiche isolante de base
- 8** Conductor connector
Connettore del conduttore
Connecteur du conducteur
- 9** Cable reducer
Riduttore cavo
Réducteur câble
- 10** Earthing lead
Messa a terra di piombo
Mise à la terre de plomb

SAREL recommends to use the following connectors as these have been tested in our RMSYS cubicle.
SAREL raccomanda di usare i seguenti connettori in quanto essi sono stati testati nei nostri quadri RMSYS.
SAREL recommande d'utiliser les connecteurs suivant considérant qu'ils ont été essayés dans les tableaux RMSYS.

Separable connectors interface C Connettori separabili interfaccia C Connecteurs séparables d'interface C I _r = 630A						
Manufacturer Produttore Producteur	Designation Denominazione Désignation	Conductor sizes Dimensioni conduttore Dimensions du conducteur (mm ²)	XLPE/EPR Ø (mm)	Earthing shield Schermo di messa a terra Blindage du mise a la terre (Yes/No)	Dual cable arrangement Disposizione cavo doppio Arrangement de câble double	Surge arrester with Con limitatori di sovratensione Avec limiteurs de surtension
EUROMOLD	K430TB	25÷300	12÷37,5	Y	K300PB	300SA
	K484TB	185÷630	23,5÷56	Y	K804PB	300SA
	K400TB/4	25÷300	12÷37,5	Y	K400CP+K400TB/G	400PB-XSA
	K440TB/4	185÷630	23,5÷56	Y	K400CP+K440TB/G	400PB-XSA
3M	93-EE 705-6/-95	50÷95	15÷23,5	Y	KU 23.2+93-EE 705-6/-95	MUT 23
	93-EE 705-6/-240	120÷240	21,8÷32,6	Y	KU 23.2+93-EE 705-6/-240	MUT 23



Norms and homologations

Norme e certificati

Normes et certificats



RMSYS switchboards have positively passed all type tests at official laboratories (CESI), according to the International Standards IEC, as well as they have obtained the peculiar homologations in others countries.

The quality system (ISO 9001- ISO 14000) assures that the whole production process maintains an high and steady quality level.

During the whole cycle of production each equipment is submitted to electrical and mechanical tests until the final test, performed as required by the IEC Standards.

Standards

- IEC 62271-200
- IEC 62271-1
- IEC 62271-103
- IEC 62271-102
- IEC 62271-105
- IEC 62271-100

I quadri RMSYS hanno positivamente superato, presso laboratori ufficiali (CESI), tutte le prove di tipo, in accordo alle Norme Internazionali IEC, oltre che aver ottenuto omologazioni specifiche di altri paesi.

Il sistema di controllo qualità (ISO 9001 - ISO 14000) assicura che l'intero processo di produzione mantenga un livello qualitativamente alto e costante.

Durante tutto il ciclo di produzione le apparecchiature sono sottoposte a prove meccaniche ed elettriche fino al collaudo finale, condotto secondo quanto previsto dalle Normative IEC.

Norme

- IEC 62271-200
- IEC 62271-1
- IEC 62271-103
- IEC 62271-102
- IEC 62271-105
- IEC 62271-100

Les tableaux RMSYS ont positivement passé dans laboratoires officiels (CESI) non seulement tous les essais de type en accord aux Normes Internationales IEC, mais aussi ils ont obtenu les homologations spécifiques d'autres pays.

Le système de contrôle qualité (ISO 9001 - ISO 14000) assure que tout le procès de production garde un niveau qualitativement haut et constant.

Pendant tout le cycle de production les équipements sont soumis aux essais électriques et mécaniques jusqu'à l'essai final, réalisé en conformité aux Normes IEC.

Normes

- IEC 62271-200
- IEC 62271-1
- IEC 62271-103
- IEC 62271-102
- IEC 62271-105
- IEC 62271-100





Technical features
Caratteristiche tecniche
Caractéristiques techniques



Due to continuous development of building materials and the updating of standards, reported data are not constricting and are subject to our revision.

Considerando l'evoluzione di materiali e norme, quanto riportato nel presente documento si potrà ritenere impegnativo solo dopo nostra conferma.

Etant donné l'évolution des matériels ainsi que des normes, les informations contenues dans le présent document, ne seront considérées comme étant valable qu'après confirmation de notre part.



RMSYS 24kV switchboard
Quadro RMSYS 24kV
Tableau RMSYS 24kV

RMSYS				
Rated voltage Tensione nominale Tension nominale		kV	12	24
Rated power-frequency withstand voltage 50Hz 1Min (kV r.m.s.) Tensione nominale di tenuta alla frequenza di esercizio 50Hz 1Min (kV eff.) Tension nominale à la fréquence industrielle 50Hz 1Min (kV eff.)	To earth and between phases Verso massa e tra le fasi Vers la terre et entre les phases	kV	28 (42)*	50 (75)*
	Across the isolating distance Sulla distanza di sezionamento Sur la distance de sectionnement		32 (48)*	60 (90)*
Rated lightning impulse withstand voltage (peak value) Tensione nominale di tenuta ad impulso atmosferico (valore di picco) Tension nominale de tenue au choc (valeur de crête)	To earth and between phases Verso massa e tra le fasi Vers la terre et entre les phases	kV	75 (75)*	125 (150)*
	Across the isolating distance Sulla distanza di sezionamento Sur la distance de sectionnement		85 (90)*	145 (165)*
Rated current main bus bars up to Corrente nominale sbarre principali fino a Courant nominale barres principales jusqu'à		A	630	
Rated current unit Corrente nominale unità funzionali Courant nominale unités fonctionnelles		A	630	
Short-time withstand current Corrente di breve durata ammissibile Courant de courte durée admissible		kA - s	20 - 3s	
Peak value Valore di picco Valeur de crête		kA	50	
Internal arc withstand Tenuta a l'arco interno Tenue à l'arc interne		kA - s	20 - 1s	
Protection degree stainless steel tank Grado di protezione tank in acciaio inox Degré de protection cuves en acier inox		IP	67	
Altitude Altitudine Hauteur		m	≤6000	
Ambient temperature Temperatura ambiente Température ambiante		°C	-5÷40	

* Data for the Russian market in accordance with GOST rules.

* Dati per il mercato russo in conformità alle normative GOST.

* Données pour le marché russe en conformité avec les règles de GOST.

Extensible typical configurations
 Configurazioni tipiche estensibili
 Configuration typiques extensibles

I - F +

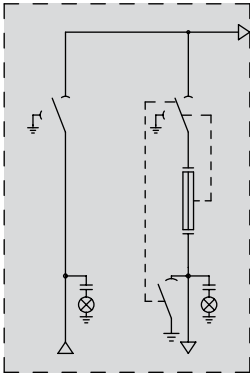

I - I - F +

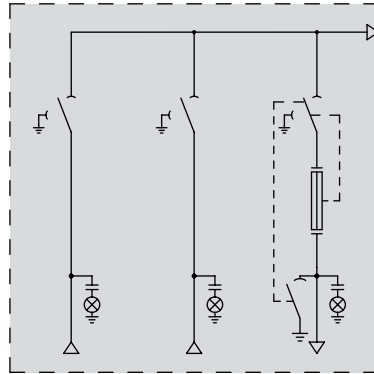

I - I - I - F +

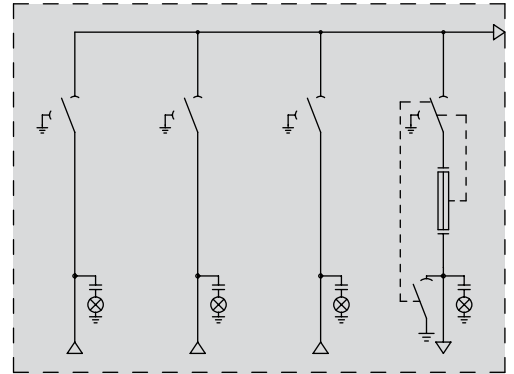

I - V +

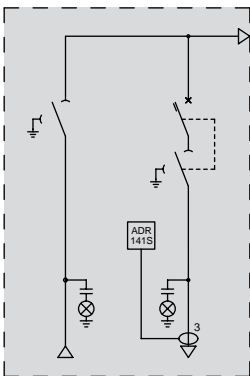

I - I - V +

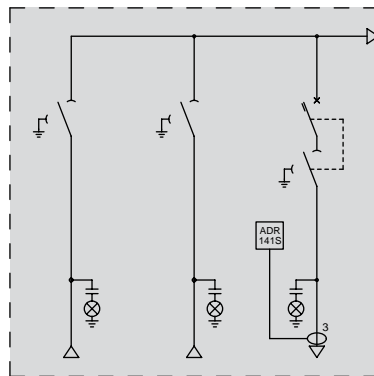

I - I - I - V +

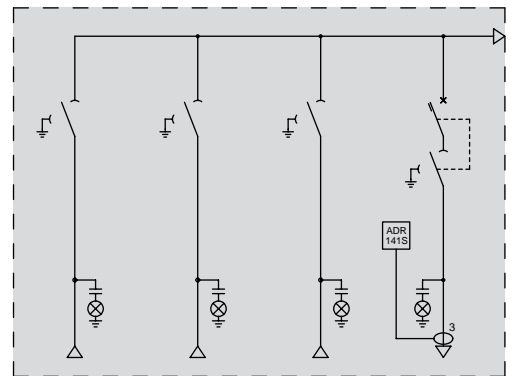

+ I +

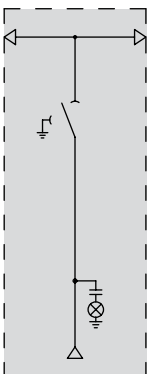

+ F

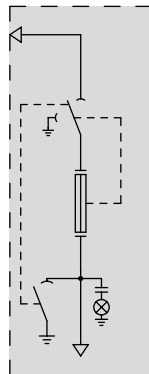

+ V

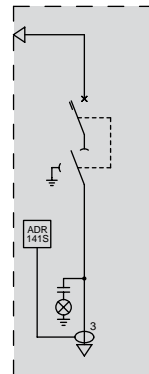

I - I - I +

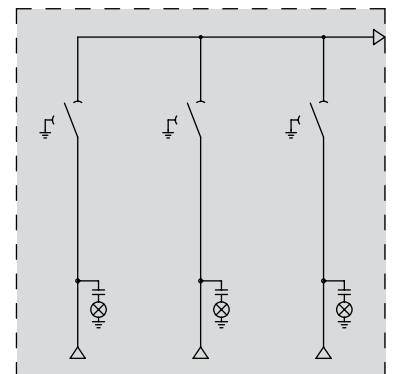

Note: Other configurations are available on request
 Nota: Altre configurazioni sono disponibili su richiesta
 Note: D'autres configurations sont disponibles sur demande

Non-extensible typical configurations
 Configurazioni tipiche non estensibili
 Configuration typiques non extensibles

I - F

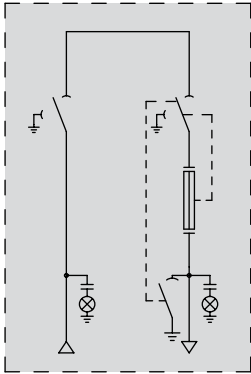

I - I - F

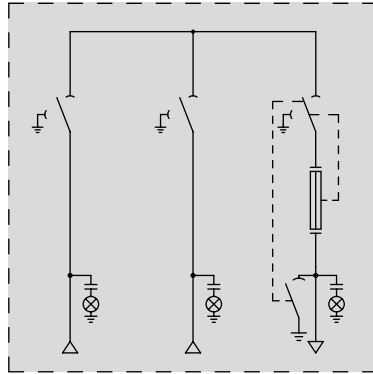

I - I - I - F

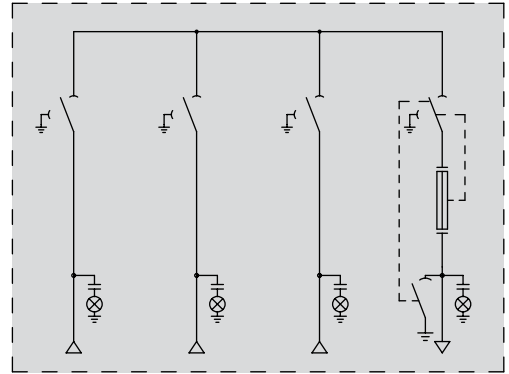

I - I - F - F

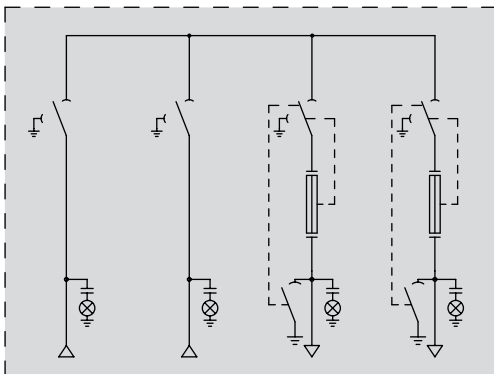

I - V

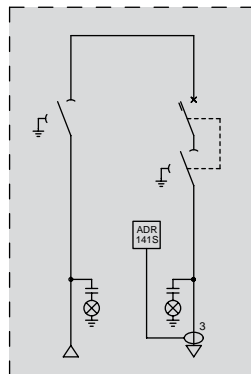

I - I - V

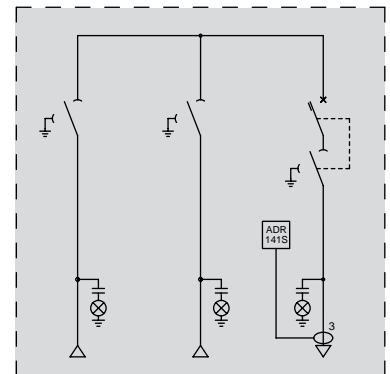

I - I - I - V

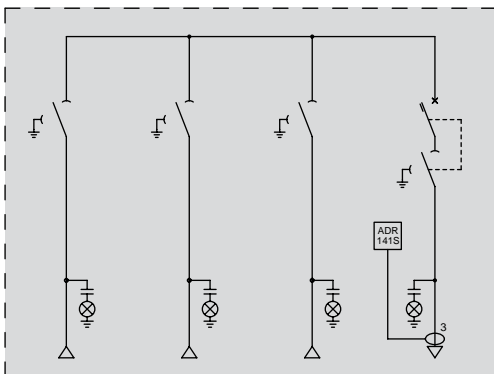

I - I - V - V

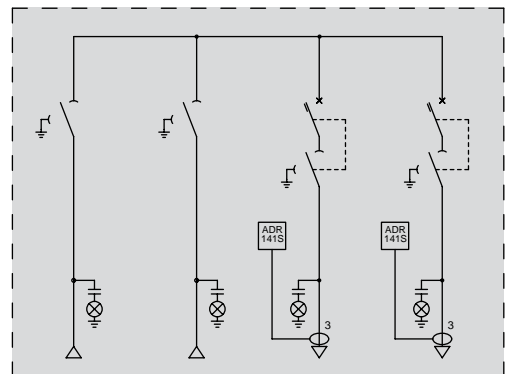

Note: Other configurations are available on request
 Nota: Altre configurazioni sono disponibili su richiesta
 Note: D'autres configurations sont disponibles sur demande

Module I

Modulo I

Module I

Incoming/outgoing with on-load switch
Ingresso/uscita con sezionatore sottocarico
Arrivée/départ avec interrupteur

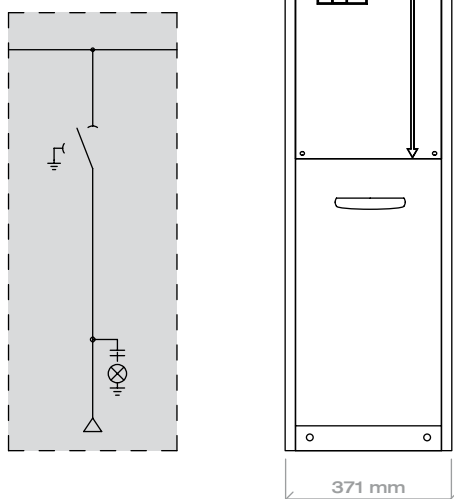

Description

- Bus bars
- Three position on-load switch (open, closed, earthed)
- Mechanical position indicator for line switch and earth switch
- Capacitive bushing isolators type C complete with voltage signalling box on the front of the panel
- Cable compartment door interlocked with the earth switch
- Earthing bar

Accessories

- Line/earth key locks
- Auxiliary contacts for line/earth switch
- Motorized operating mechanism with auxiliary contacts for line/earth
- Connector for extension on left/right side

Descrizione

- Sistema di sbarre
- Sezionatore sotto carico a tre posizioni (aperto, chiuso, a terra)
- Indicatore di posizione meccanico per sezionatore di linea e di terra
- Isolatori passanti capacitivi tipo C completi con scatoletta di segnalazione presenza tensione sul fronte del quadro
- Porta di accesso al vano cavi interbloccata con il sezionatore di terra
- Sbarra di terra

Accessories

- Blocchi a chiave linea/terra
- Contatti ausiliari per sezionatore di linea/terra
- Comando motorizzato con contatti ausiliari di linea/terra
- Connettori per estensione sui lati

Description

- Jeu de barres
- Interrupteur à trois positions (fermé, ouvert, mise à la terre)
- Indicateur mécanique de position interrupteur de ligne et de terre
- Isolateurs passant capacitifs type C avec boîte de signalisation présence tension sur le front panneau
- Porte d'accès au compartiment câbles verrouillée avec l'interrupteur de mise à la terre
- Barre de mise à la terre

Accessories

- Verouillage à clé ligne/terre
- Contacts auxiliaires pour interrupteur de ligne/terre
- Commande motorisée avec contacts auxiliaires de ligne/terre
- Connecteurs pour extension sur les côtés

Module F

Modulo F

Module F

Transformer protection with on-load switch-fuse combination

Protezione trasformatore con sezionatore-fusibile combinato

Protection transformateur avec interrupteur-fusible combiné

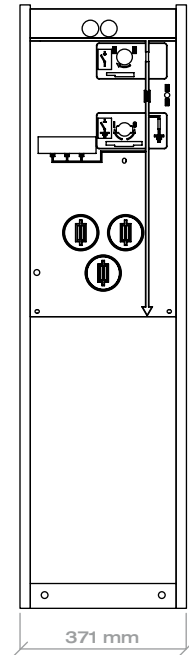
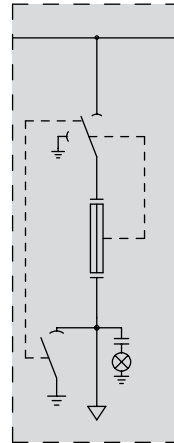

Description

- Bus bars
- Three position on-load switch (open, closed, earthed)
- Housing for DIN type fuses
- Earth switch at the top and at the bottom of the fuses
- Mechanical position indicator for line switch and earth switch
- Capacitive bushing isolators type C complete with voltage signalling box on the front of the panel
- Cable compartment door interlocked with the earth switch
- Earthing bar

Accessories

- Line/earth key locks
- Auxiliary contacts for line/earth switch
- Opening coil with auxiliary contacts for line/earth switch
- Motorized operating mechanism with auxiliary contacts for line/earth
- Auxiliary contact for fuse blow-up indication
- Connector for extension on left/right side

Descrizione

- Sistema di sbarre
- Sezionatore sotto carico a tre posizioni (aperto, chiuso, a terra)
- Alloggiamento per fusibili tipo DIN
- Sezionatore di messa a terra a monte e a valle dei fusibili
- Indicatore di posizione meccanico per sezionatore di linea e di terra
- Isolatori passanti capacitivi tipo C completi con scatoletta di segnalazione presenza tensione sul fronte del quadro
- Porta di accesso al vano cavi interbloccata con il sezionatore di terra
- Sbarra di terra

Accessories

- Blocchi a chiave linea/terra
- Contatti ausiliari per sezionatore di linea/terra
- Bobina di apertura con contatti ausiliari di linea/terra
- Comando motorizzato con contatti ausiliari di linea/terra
- Contatto ausiliario per l'indicazione di fusione fusibile
- Connettori per estensione sui lati

Description

- Jeu de barres
- Interrupteur à trois positions (fermé, ouvert, mise à la terre)
- Logement pour les fusibles type DIN
- Interrupteur de m.a.t. à mont et aval des fusibles
- Indicateur mécanique de position interrupteur de ligne et de terre
- Isolateurs passant capacitifs type C avec boîte de signalisation présence tension sur le front panneau
- Porte d'accès au compartiment cables verrouillée avec l'interrupteur de mise à la terre
- Barre de mise à la terre

Accessories

- Verouillage à clé ligne/terre"
- Contacts auxiliaires pour interrupteur de ligne/terre
- Bobine d'ouverture avec contacts auxiliaires de ligne/terre
- Commande motorisée avec contacts auxiliaires de ligne/terre
- Contact auxiliaire pour indication fusion fusible
- Connecteurs pour extension sur les côtés

Module V

Modulo V

Module V

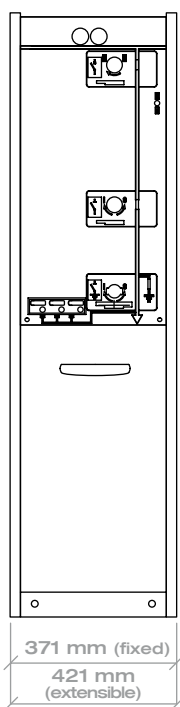
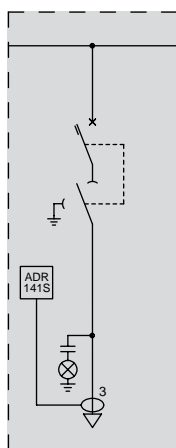

Transformer protection with
vacuum circuit breaker
Protezione trasformatore con
interruttore sottovuoto
Protection transformateur avec
disjoncteur sous vide

Description

- Bus bars
- Three position on-load switch (open, closed, earthed)
- Vacuum circuit breaker mechanically interlocked with the on-load switch
- Mechanical position indicator for the VCB, line switch and earth switch
- Self-powered protection relay with self-powered opening coil
- Capacitive bushing isolators type C complete with voltage signalling box on the front of the panel
- Cable compartment door interlocked with the earth switch
- Earthing bar

Accessories

- Line/earth key locks
- Auxiliary contacts for line/earth switch
- Auxiliary contacts for VCB
- Opening coil for VCB with auxiliary contacts
- Motorized operating mechanism for VCB and on-load switch with auxiliary contacts
- Auxiliary contact for self-powered relay trip indication
- Connector for extension on left/right side

Descrizione

- Sistema di sbarre
- Sezionatore sotto carico a tre posizioni (aperto, chiuso, a terra)
- Interruttore sottovuoto interbloccato meccanicamente con il sezionatore sotto carico
- Indicatore di posizione meccanico per interruttore, sezionatore di linea e di terra
- Relè di protezione autoalimentato con bobina di apertura autoalimentata
- Isolatori passanti capacitivi tipo C completi con scatoletta di segnalazione presenza tensione sul fronte del quadro
- Porta di accesso al vano cavi interbloccata con il sezionatore di terra
- Sbarra di terra

Accessories

- Blocchi a chiave linea/terra
- Contatti ausiliari per sezionatore di linea/terra
- Contatti ausiliari per interruttore
- Bobina di apertura per interruttore con contatti ausiliari
- Comando motorizzato per interruttore e sezionatore con contatti ausiliari
- Contatto ausiliario per la segnalazione di intervento relè autoalimentato
- Connettori per estensione sui lati

Description

- Jeu de barres
- Interrupteur à trois positions (fermé, ouvert, mise à la terre)
- Disjoncteur sous vide verrouillé mécaniquement avec l'interrupteur
- Indicateur mécanique de position pour disjoncteur, interrupteur de ligne et de terre
- Relais de protection autoalimenté avec bobine d'ouverture autoalimenté
- Isolateurs passant capacitifs type C avec boîte de signalisation présence tension sur le front panneau
- Porte d'accès au compartiment cables verrouillée avec l'interrupteur de mise à la terre
- Barre de mise à la terre

Accessories

- Verouillage à clé ligne/terre
- Contacts auxiliaires pour interrupteur de ligne/terre
- Contacts auxiliaires pour disjoncteur
- Bobine d'ouverture pour disjoncteur avec contacts auxiliaires
- Commande motorisée pour disjoncteur et interrupteur avec contacts auxiliaires
- Contact auxiliaire pour signalisation intervention relais autoalimenté
- Connecteurs pour extension sur les côtés

Module M

Modulo M

Module M

Metering module with CT and VT
 Modulo misure con TA e TV
 Mesure avec TC e TT

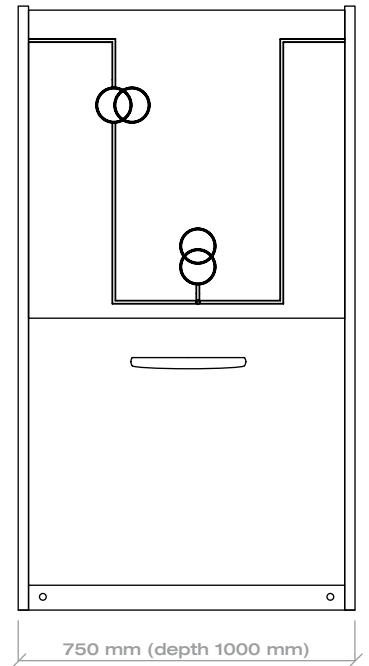
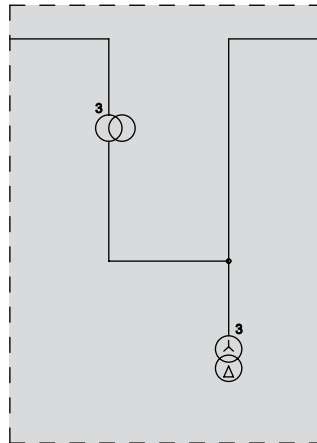

Description

- Bus bars
- 3 voltage transformers
- 3 current transformers
- Low voltage auxiliary compartment
- Heater resistance with thermostat

Accessories

- Terminal set for seal

Descrizione

- Sistema di sbarre
- 3 riduttori di tensione
- 3 riduttori di corrente
- Cassonetto circuiti ausiliari
- Resistenza anticondensa con termostato

Accessories

- Morsettiera sigillabile tipo MC3

Description

- Jeu de barres
- 3 transformateurs de tension
- 3 transformateurs de courant
- Coffret pour circuits auxiliaires
- Résistance de chauffage avec thermostat

Accessories

- Borne d'essai scellable type MCB

Placement and civil works
Posizionamento e opere civili
Positionnement et ouvrages civils

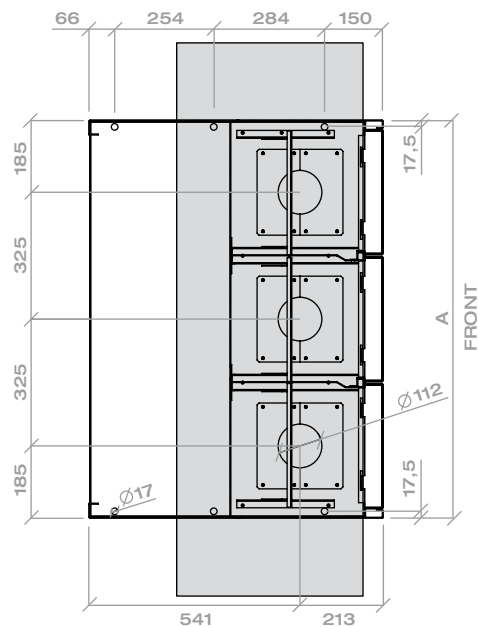
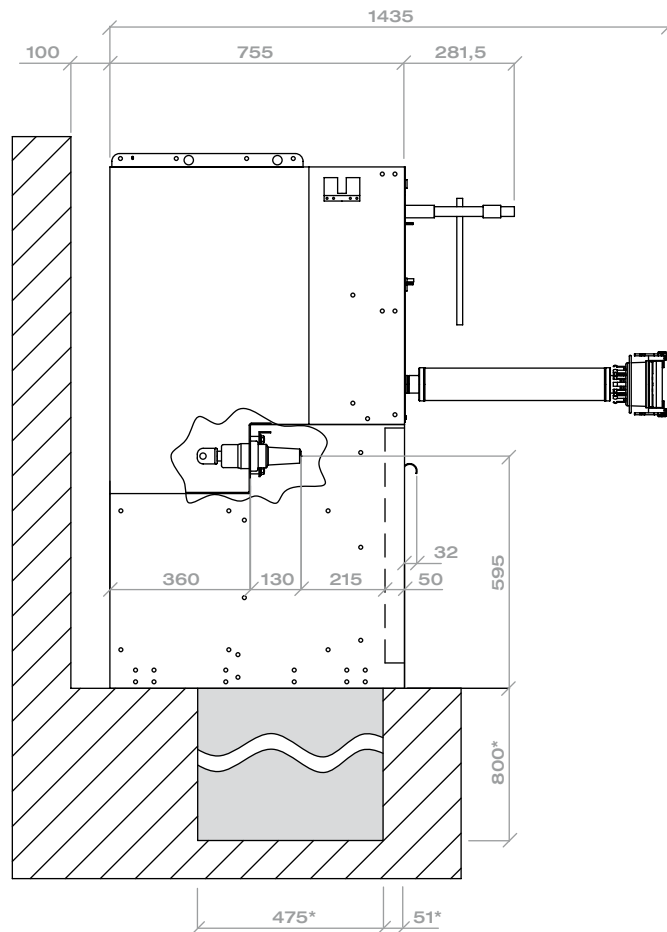

* Recommended indicative values
* Valori indicativi consigliati
* Valeurs indicatives recommandées



Fuse type

Tipo con fusibili

Type avec fusibles

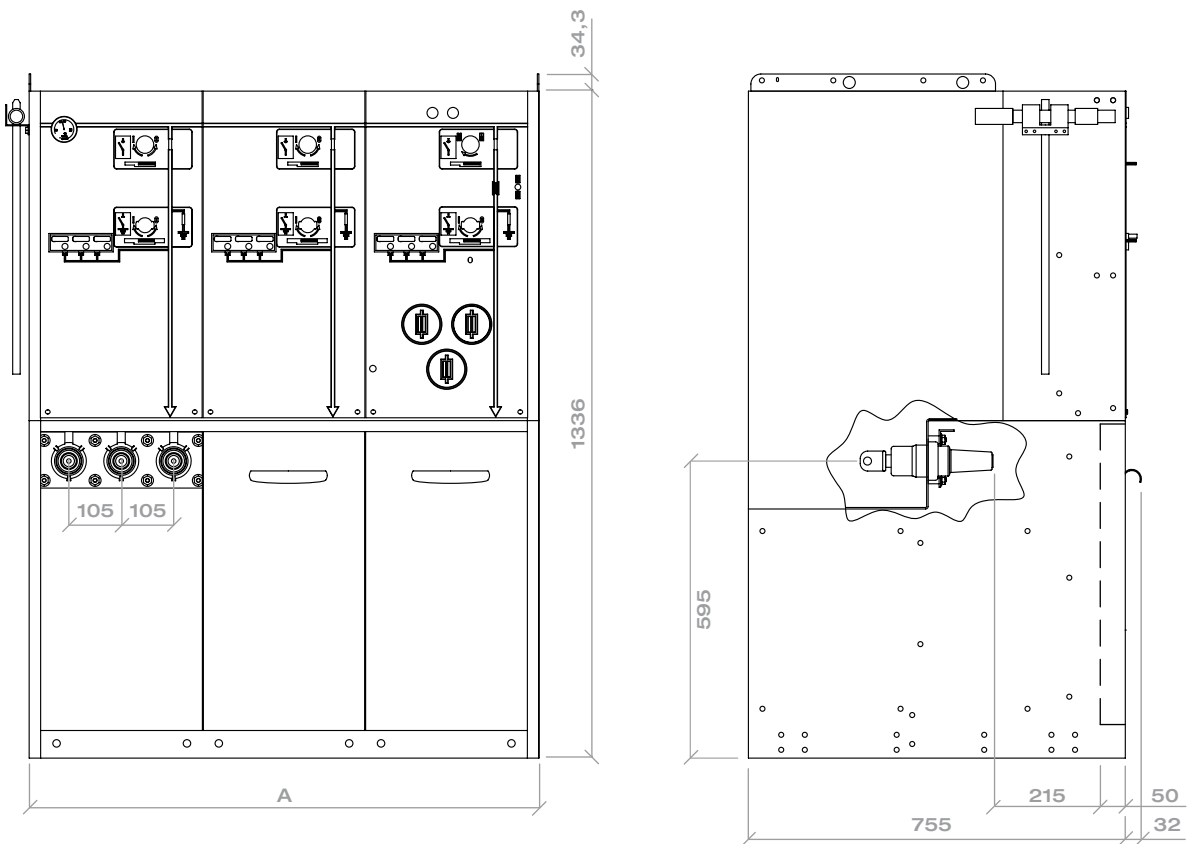

Dimensions and weight | Dimensioni e pesi | Dimensions et poids

Type	Fixed		Extensible (+)	
	A (mm)	Kg	A (mm)	Kg
I - F (+)	696	270	696	278
I - I - F (+)	1021	363	1021	371
I - I - I - F (+)	1346	458	1346	466
I - I - F - F (+)	1346	540	1346	548
+ I +	/	/	371	145
+ F	/	/	371	185
I - I - I +	/	/	1021	292

Vacuum circuit
 breaker type

Tipo con interruttore
 sottovuoto

Type avec disjoncteur
 sous vide

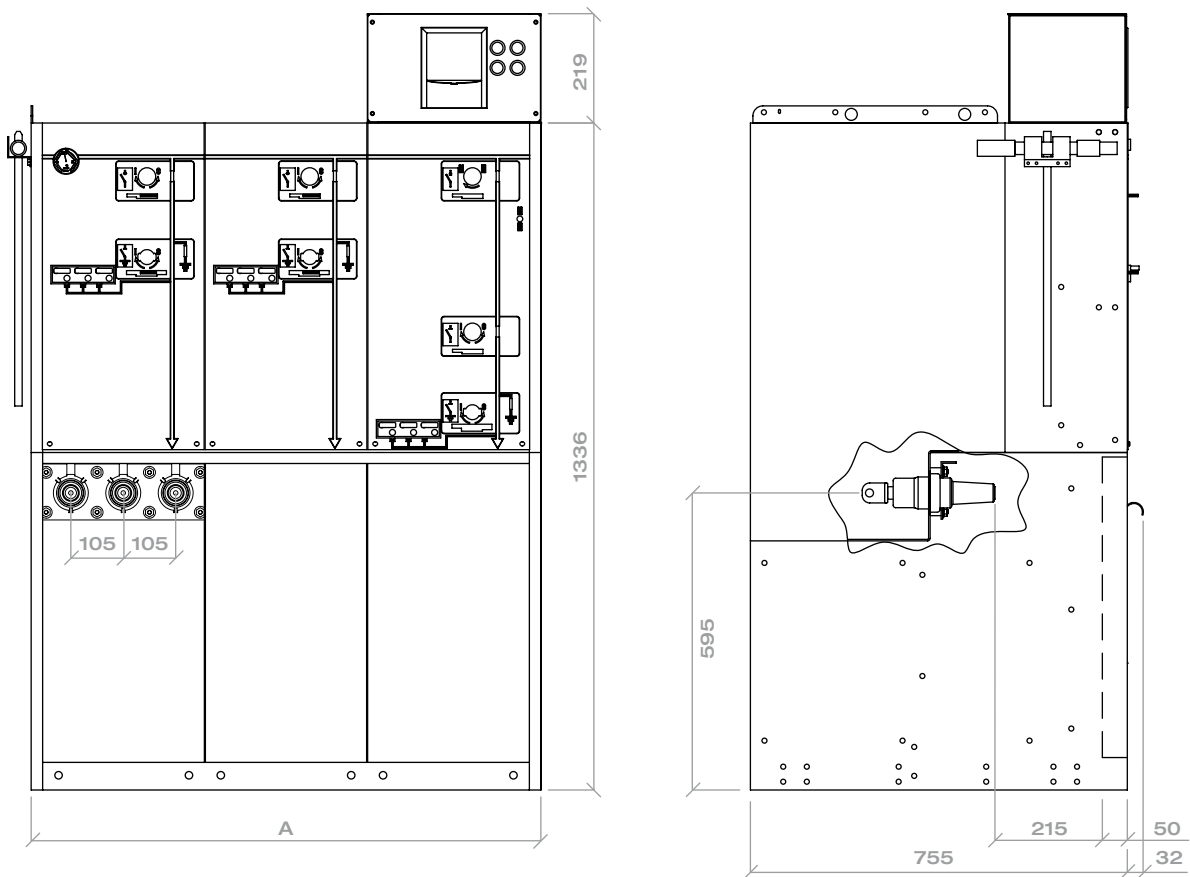

Dimensions and weight | Dimensioni e pesi | Dimensions et poids

Type	Fixed		Extensible (+)	
	A (mm)	Kg	A (mm)	Kg
I - V (+)	696	279	746	287
I - I - V (+)	1021	372	1071	380
I - I - I - V (+)	1346	467	1396	475
I - I - V - V (+)	1346	558	1396	566
+ V	/	/	421	205



For energizing the world

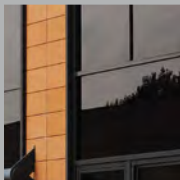
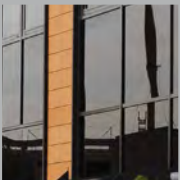
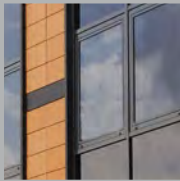
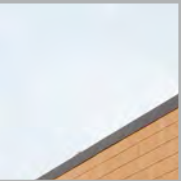



Via del Commercio, 12/14
26900, Lodi (LO), Italy

Tel. +39 0371 49061
Fax +39 0371 411422

info@sarel.it
www.sarel.it